

WhitePaper

Critical-Path Electrical Cabling ver. 1.0

“secured power provisioning for power-hungry devices”

Residential electrical cabling for power-hungry devices only differs slightly from their low-power counterparts. In fact, heavier fuses and slightly thicker wirings are the only differences. Our Critical-Path electrical cabling for heavy electrical loads go much further. They deliver massive amounts of energy using super additional sensitive Residual Current protective devices (e.g. differential current detection) and Arc Fault detection. It is our goal to provide our customers with the very best and safest electrical systems possible.

Almost 20% of in-house fires are due to faulty electrical devices and/or bad contacts (source: CBS “Brandweer statistiek 2009”). That is why Van Welleman Villas® puts such efforts into the prevention of poor contacts and the detection of Arcing Faults (i.e. electrical arcs due to faulty contacts).

Our Critical-Path electrical cabling is optimized for power-hungry devices (typically 3KW and above) such as the dishwasher, oven, etc. Critical Path electrical cabling uses a “star” topology (also see white-paper “Safe-Path Electrical Cabling”) in which all power-hungry devices are connected directly to the power-closet (i.e. fuse-box).

The following measures increase electrical safety, fire safety, and mains redundancy :

- All outlets are connected directly to the power closet.
- Power loads get individual 4mm² cable for extra margin.
- High -power loads get individual 6mm² for extra margin.
- Junctions are soldered instead of screwed.
- Critical cables get fire-proof silicon insulation.
- All cables run in grounded metal gutters for extra safety.
- Critical technical ducts have fire detection.
- Only 32Amp industrial sockets are used.
- Only high-current circuit breakers are used (10K Amp!).
- All segments are backed by an extra NEOZED-fuse, should contacts of a circuit breaker “block” due to a contact-melt as a result of an excessive short-circuit.
- User-notification upon alarm activation (i.e. power still on).
- All segments have individual arcing-fault detection for fire prevention.

All of the measures above lead to electrical systems with far better protection against fire, damage and assault. As such, they play an important role in our fire-prevention strategy as well.

Although some of these measures might seem exaggerated, it is our conviction that it is better to prevent than to cure. That is why we do not rely on sole security measures (e.g. a circuit breaker), instead we use staffed safety features (thicker wire + circuit barker + fuse + arcing fault detection) providing super-safe electrical systems.

Traditional Circuit Breaker

The picture below shows a traditional circuit breaker of 16Amp with a contact-melt at 3.000 Amp.

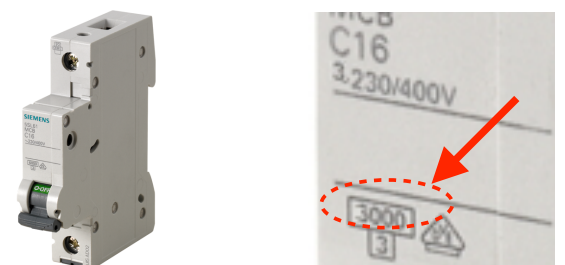

High-Current Circuit Breaker

The picture below shows a circuit breaker of 16Amp with a contact-melt at 10.000 Amp. Looks exactly the same as above, but operates much safer.

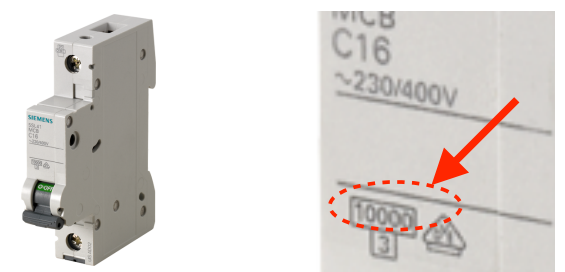

Industrial NEOZED-fuse

Fuses ensure safe and fast disconnection, minimizing the damaging effects of a short-circuit. Fuses do not suffer from contact-melting and are therefore the ideal backup for circuit-breakers.



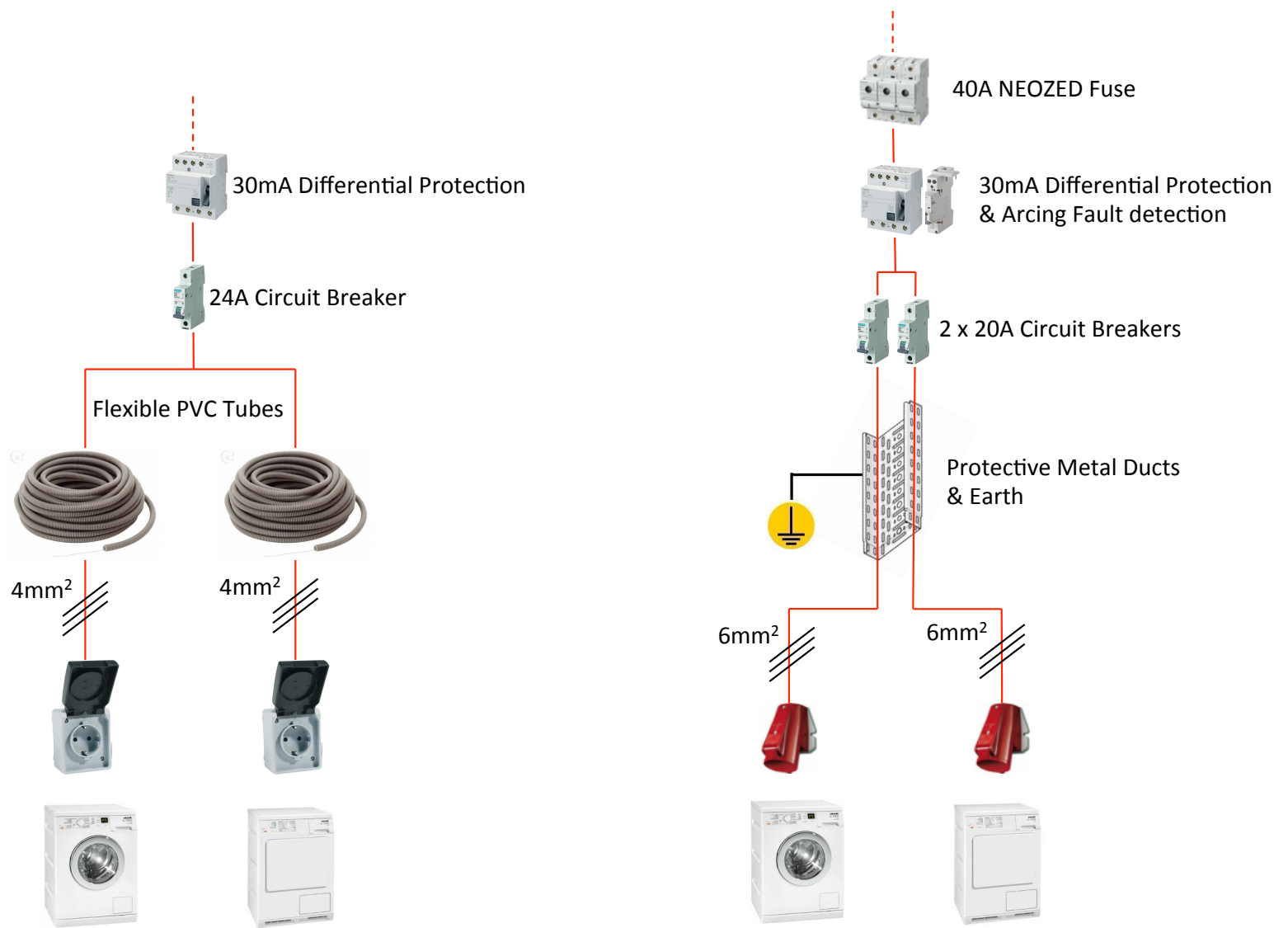

fig 1. Traditional (left) versus Critical-Path (right) electrical cabling. (220VAC / 16Amp example)

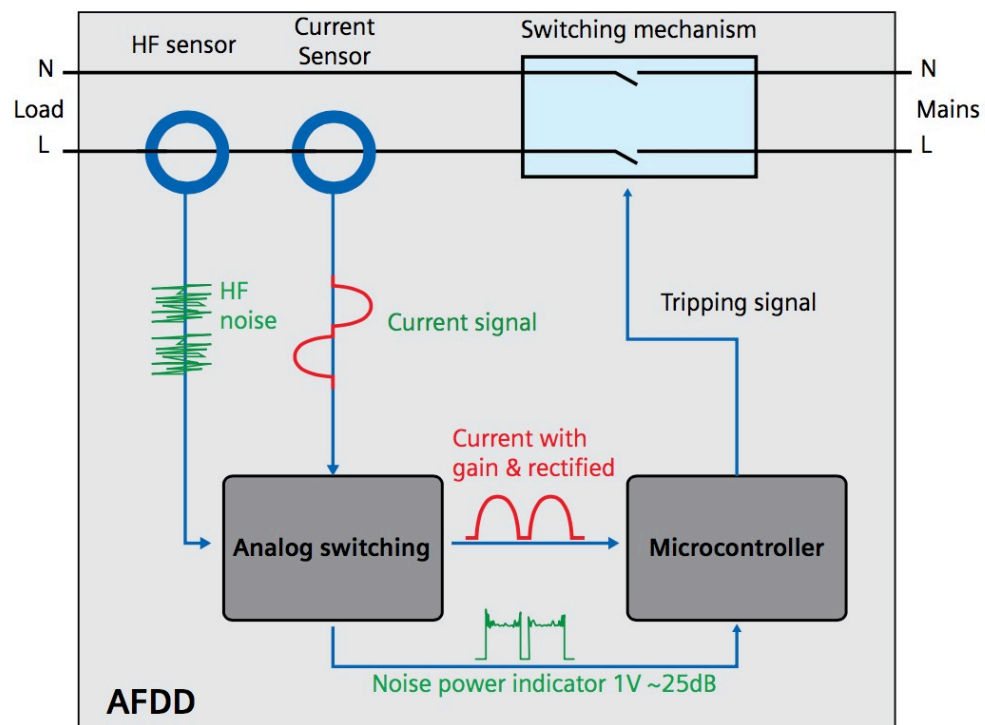

fig 2. Arcing Fault detection principle. (Source: Siemens)