

Abstract Submerged Multimedia ver. 1.0

“exiting experiences without disturbance”

Our commitment to perfection is far from limited to construction-related topics or life threatening issues (as described in our Position Papers). Van Welleman Villas® also commits to pure indulgence of its customers. Some of them will -for instance- enjoy our high power kitchen counters (e.g. see related WhitePaper), others prefer watching movies in near-ideal circumstances. This abstract shows how indulgence, quality and safety can be integrated under the form of Submerged Multimedia.

There are many extremely exclusive and mind-blowing home cinemas around. Glittering rooms with tilting leather seats and exclusive wall coverings that cost a small fortune are no exceptions to the rule. However, although we have the partners with the skills to provide those exclusive rooms, that is not our primary focus.

The primary focus of Van Welleman Villas®' Submerged Multimedia is not the ultimate in exclusivity, instead we aim for perfection in Safety, Quality and Comfort. Whereas exclusivity focuses on the “wow” effect, we focus on how to come as close as possible to the “perfect” listening and/or projection environment. And all of this in the safest and most comfortable circumstances ... for all inhabitants (including those NOT participating the show).

Vibrating leather seats and high Sound Pressure Levels might seem impressive, the fact however remains that they feel cold, reflect ambient light (the leather), they are bad for your ears (high SPL), and they disturb the other inhabitants (vibrations and contact sounds). On top of all, these environments are potentially unsafe since high SPLs might prevent you from hearing a fire detection alarm.

Our Submerged Multimedia proposal is a multitude of measures and solutions that enable our customers to watch movies in near-ideal circumstances, listen to music almost as if they would sit in the Recording Studio, have the best possible power available for connecting their high-end amplifiers ... and all of this in the best and safest possible circumstances. A lightning hitting the power line nearby, smoke in a room, an unwanted individual trespassing your private surroundings, a hacker nearby ... all of these -and many others- will not bring our customers (nor their equipments) in unpleasant or harmful situations.

For customers requiring even more exclusivity, specialized partners will be involved. However, Van Welleman Villas® will always supervise the selection, ensuring usage of fire retarding materials, integration with security systems, etc.

Should this “Abstract” trigger your hunger for more information then there are a multitude of “White-Papers” available containing more detailed information on our solutions enabling pure indulgence in the best and safest environments possible.

Dark Space Media Cinematographics

A Dark Space Media® cinematographic room's only purpose is to come as close as possible to the ideal projection room (i.e. deep space with no reflections).

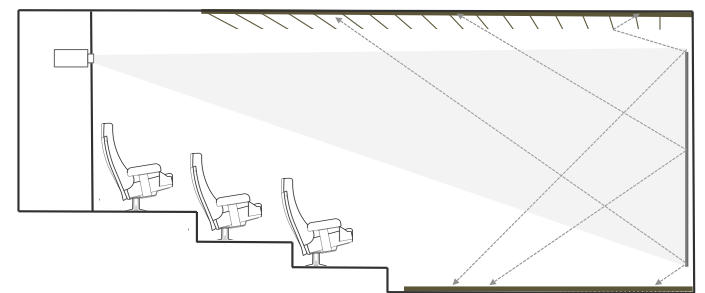

Kinetic-Neutral Resonance Seats

Kinetic-neutral resonance is used to minimize the amount of vibrations towards the foundations. Maximum pleasure for the audience, minimal disruption for the inhabitants.

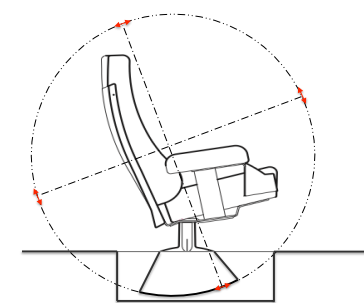

Clean Power Provisioning

A separate -isolated- power segment is reserved for your high power electronics such as High-End power amplifiers or powerful THX multichannel audio systems.



What makes Van Welleman Villas® different ...

Dark Space Media Cinematographics

Dark Space Media® is all about the creation of an optical-dead dark space, as if you would float in the cosmos with no ambient light whatsoever. Traditional cinemas use cloth-based materials for floors, walls and ceilings. Although optimized for acoustic performance, they perform poor for optical performance. Dark Space Media Cinematographics use special wall-coverings, floors, as well as ceilings that eliminate optical reflections as much as possible. As such the dark spaces on the white projection screen become darker (increased contrast).

Kinetic-Neutral Resonance

Generating low frequencies at high Sound Pressure Levels make you vibrate and -as such- provides the audiovisual pleasure. Adding seat-vibrating units (e.g. “buttkickers”) even enhances the experience. Unfortunately, these low frequencies are very difficult to isolate from the surrounding rooms, which makes it unpleasant for the other inhabitants. Kinetic-Neutral Resonance makes seats -and their spectators- vibrate at their resonance frequency (requires very low power) and around their gravitational centre (very low transfer to the environment). The effect of “submersion” is exactly the same, but the amount of low frequency energy to be isolated is only a fraction of traditional systems. As such, the other inhabitants enjoy silence while you get shaken. Also, this method enhances the perception of being surrounded by high sound pressure levels ... but that is just a perception. As such, we create high emotional participation in the audiovisual action, which remains healthy for your ears, and pleasant for the rest of your family.

Integrated Cinematographic Ambient Control

An integrated control of the security automation system with the multimedia system of your home cinema enables an enhanced perception (i.e. through Dark Space Media and Kinetic-Neutral Resonance) by controlled environmental distortion. As an example, the “EXIT” indication lights only illuminate when needed, projection stops upon potentially unsafe or hazardous situations (e.g. smoke, gas, alarm, ...), ambient lights illuminate informing you of visitors or other inhabitants arriving ...

End-to-End Acoustic Isolation

Our acoustic isolation is not just limited to some caustic damping panels in the cinematographic environment. At Van Welleman Villas® all stages of the construction project are inherent part of the acoustic design. This starts with avoiding high energy sounds to be created (e.g. Kinetic-Neutral Resonance). Second, simple measures -such as selecting the type of materials used for walls and foundations- are taken to make it difficult for parasitic noises to propagate. We also take great care defining the right shape of the rooms, as such avoiding resonance and standing waves as much as possible. Next, special isolation accessories such as dampers and floating screed are used to avoid contact sounds to travel through the construction. Finally, more advanced technologies are used for environmental optimization (for video, audio or others).

High-Speed dedicated LAN for Media Streaming

Multi-media gets a dedicated high-speed switched network which is totally isolated from all other networks. The latter is to avoid that hacker use the Internet connection (required for streaming) to access the home automation system. Routers, firewalls, but also PC's, tablets, or any Internet connected device are -by default- considered as unsafe devices.

Clean Power Provisioning

Clean power provisioning starts with “details”, up to “serious” protective measures. Such a measure is the fact that all our outlets always have the phase at the right side (looking into the outlet). Although a “detail” for most of us, High-End audio specialists know that this has a positive impact on audio quality. Other measures are industrial surge suppressors, “safe-path” electrical cabling, low impedance segments, ...

High-End cable ducts

The real HiFi passionate does not use traditional loudspeaker cable. Instead he uses extremely thick and specially coated cables ... that do not fit in traditional electricity tubes in the walls. We provide special tubes and ducts for those demanding situations. Also, our technical ceilings provide an additional flexibility for future modifications.